

Separate catalog available

Note 1 : If the traverse stroke (B) is 2,200 or more, a support is needed.

HSA-250S

Pursuing a lighter, thinner, and vibration-resistant body for world top-class speed



For CE supported languages, please contact our sales department.

- Clamping force **180 - 300tf**
- Super-high speed
- Vibration control
- Optimized design + Power-saving
- Low posture (Double speed mechanism)
- All-axis servo-driven

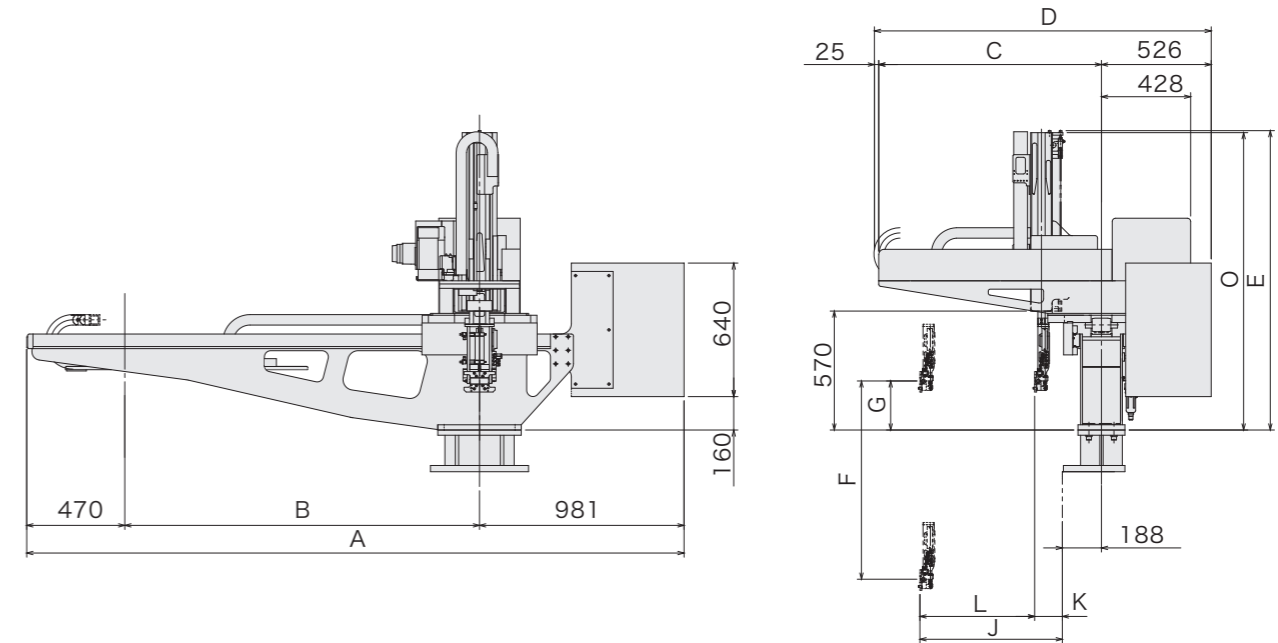

[mm]

Model	A	B	C	D	E	F	G	J	K	L	O
HSA-250S	3151 (3351) (3651) (3951)	1700 (1900) (2200) (2500)	1278	1829	(1387) 1435 (1515) (1611)	(850) 950 (1100) (1300)	235	893	133	760	(1377) 1425 (1505) (1601)

() : Modified stroke

High-Speed Robot with Optimized, Lightweight Design

The HSA incorporates design optimizations for higher speed and rigidity with less weight. With take-out times as fast as 0.27 seconds proven during live molding, the HSA is 13% lighter*1 and 25% faster than previous models.

Slimmer, Optimally-Designed End-of-Arm Tool Fits Through Narrower Mold Openings

Yushin applied design optimizations to the end-of-arm tool flip unit (the arm end which enters the mold) to make it 38% slimmer*1. The thinner arm allows operators to shorten mold openings by up to 41 mm, which helps accelerate molding cycles.

Vibration Control Technology Tames Arm Flutter

The HSA features vibration-reducing technology throughout its construction, including optimally-designed end-of-arm tools and a take-out arm reinforced with CFRP (carbon fiber reinforced plastic) for superior vibration-damping.

*1 Measurements above are relative to previous comparable models.

Standard Specifications

Power supply	Drive method	Controller model	Working air pressure	Flip angle			
200/220 VAC (50/60 Hz) 3 phase	Digital servo motor 3-axis	E-touch II-K/ E-touch compact II	0.49MPa	90°			
Model	Power consumption	Traverse stroke [mm]	Kick stroke [mm]	Vertical stroke [mm]	Air consumption [NL/cycle]	Payload [kg]	Target IMM clamp capacity [tf]
			Main arm	Main arm			
HSA-250S	6.1 kVA 3 phase 200 VAC 17.5 A Max.	1700 (1900) (2200) (2500)	760	950 (850) (1100) (1300)	9.8 ECO Vacuum OFF 3.6 ECO Vacuum ON	5	180-300

S type : Robot is equipped with main arm only.

() : Modified stroke

Stanchion is standard equipment for 2,200 mm or longer traverse stroke.

Payload includes the end-of-arm tool.